

Retinal Image Analysis for Abnormality Detection-An Overview

¹Karthikeyan, R. and ²P. Alli

¹Department of CSE,
PSNA College of Engineering and Technology Dindigul,
TamilNadu, India

²Department of CSE,
Velammal College of Engineering and Technology, Madurai,
TamilNadu, India

Abstract: Problem statement: Classification plays a major role in retinal image analysis for detecting the various abnormalities in retinal images. Classification refers to one of the mining concepts using supervised or unsupervised learning techniques. **Approach:** Diabetic retinopathy is one of the common complications of diabetes. Unfortunately, in many cases, the patient is not aware any symptoms until it is too late for effective treatment. Diabetic retinopathy is the leading cause of blindness. Diabetic retinopathy results in retinal disorders that include microaneurysms, drusen, hard exudates and intra-retinal micro-vascular abnormalities. **Results:** An automatic method to detect various lesions associated with diabetic retinopathy facilitate the ophthalmologists in accurate diagnosis and treatment planning. Abnormal retinal images fall into four different classes namely Non-Proliferative Diabetic Retinopathy (NPDR), Central Retinal Vein Occlusion (CRVO), Choroidal Neo-Vascularization Membrane (CNVM) and Central Serous Retinopathy (CSR). **Conclusion:** In this study, we have analyzed the various methodologies for detecting the abnormalities in retinal images automatically along with their merits and demerits and proposed the new framework for detection of abnormalities using Cellular Neural Network (CNN).

Key words: Classification, diabetic retinopathy, retinal disorder, NPDR, CRVO, CNVM, CSR, Cellular Neural Network (CNN), diabetic retinopathy

INTRODUCTION

Diabetic Retinopathy (DR) is a sight threatening complication due to diabetes mellitus that affects the retina. There are five levels of DR severity, namely no DR, mild Non-Proliferative Diabetic Retinopathy (NPDR), moderate NPDR, severe NPDR and Proliferative Diabetic Retinopathy (PDR). According to the Malaysia National Eye Database 2007, among 10,856 cases with diabetes, 36.8% has any form of DR, of which 7.1% comprises Proliferative Diabetic Retinopathy (PDR) (Hani *et al.*, 2010). At first, the people suffering with DR may notice no changes in their vision. It could get worse over the years and threaten their good vision (Sivakumar *et al.*, 2003).

Diabetic Retinopathy (DR) remains one of the leading causes of blindness and vision defects in developed countries. There exist effective treatments that inhibit the progression of the disease provided that

it would be diagnosed early enough. But DR is usually asymptomatic in its beginning, so diabetic patients do not undergo any eye examination until it is already too late for an optimal treatment and severe retinal damages have been caused. Regular retinal examinations for diabetic patients guarantee an early detection of DR reducing significantly the incidence of blindness cases. Because of great prevalence of diabetes, mass screening is time consuming and requires many trained graders to examine the fundus photographs searching retinal lesions. A reliable method for automated assessment of the presence of lesions in fundus images will be a valuable tool in assisting the limited number of professional and reducing the examination time (Sanchez *et al.*, 2004).

Now-a-days the information amount the medic has to deal with is huge. Therefore, a careful and detailed analysis of such a data is hardly possible. In the medical context, the problem arises while making the medical

Corresponding Author: Karthikeyan, R., Department of CSE, PSNA College of Engineering and Technology Dindigul, TamilNadu, India

decision when the state of the patient has to be assigned to the initially known class. In most of the cases, the boundaries between the different abnormal classes are not straightforward which further add to the complexity. These classification problems are specific in the case of ophthalmologic applications. In ophthalmology, eye fundus examinations are highly preferred for diagnosing the abnormalities and follow-up of the development of the eye disease. But the problem of diagnosis lies in the huge amount examinations which has to be performed by the specialists to detect the abnormalities. An automated system based on neural computing overcome this problem by identifying automatically all the images with abnormalities (Anitha *et al.*, 2009a).

If the disease is detected in its early stages, laser photocoagulation can slow down the progression of DR. However, this is not easy because DR is asymptomatic in these stages. To ensure that treatment is received on time, the eye fundus of diabetic patients needs to be examined at least once a year. The growing incidence of diabetes, the high cost of examinations and the lack of specialists increase the work load of physicians and prevent many patients from receiving effective treatment. Automatic detection of clinical signs of DR can help ophthalmologists in the diagnosis of the disease, with the subsequent cost and time savings (Garcia *et al.*, 2007).

There are different kinds of abnormal lesions caused by diabetic retinopathy such as microaneurysm, hard exudate, soft exudate, hemorrhage and neo-vascularization. Microaneurysms are the earliest clinically detectable lesions. Figure 1 show the retinal image affected by diabetic retinopathy with microaneurysms as an abnormal lesion.

These are very important for classifying whether images show signs of retinopathy. Neo-vascularization is a serious abnormality type. It consists in the formation of new blood vessels that are weak and can easily break, causing hemorrhages. Hard exudates are lipid formations leaked from weakened vessels and appear in clusters. Soft exudates are due to obstruction of retinal arterioles (Hani *et al.*, 2010).

Early detection of DR through screening can prevent blindness and allow for maintenance of good vision. A typical screening process involves the acquisition of retinal images from the patient followed by manual examination of each individual image by medical experts (these are actually often technicians trained by medics) in order to identify any signs of deterioration. This process is known to be inefficient, expensive and time consuming. These few reasons alone make the development of an automated system imperative (Goh *et al.*, 2009).

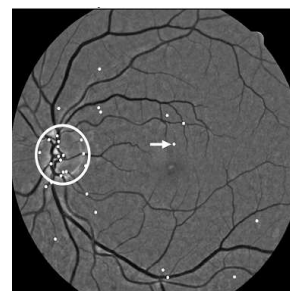

Fig. 1: Microaneurysm in retinal image

Classification of the severity of diabetic retinopathy and quantification of diabetic changes are vital for assessing the therapies and risk factors for this frequent complication of diabetes. The earlier clinical studies use the standardized, validated Wisconsin grading system of retinopathy which is performed by an experienced ophthalmologist or grader using standard photographs. This method is a time-consuming process which requires significant training and exercise and is vulnerable to observer error (Ngyen *et al.*, 1996). Therefore, efficient classifiers for automatic detection of DR are playing a vital role in the field of image mining.

In this study, we have discussed the various methodologies to detect and quantify lesions associated with Diabetic retinopathy as well as classification schemes for classifying the severity of DR.

MATERIALS AND METHODS

Abnormality in retinal images can be detected by the classifying the various abnormal lesions based on their severity. The classification scheme for classifying the retinal image database for detecting its abnormalities is given below:

Retinal image database: The basic components of the image classification system are retinal image database, pre-processing, feature extraction and classifiers. For the image data set, the retinal images are acquired from any standard retinal image database such as STARE, DRIVE or from any well-known eye hospitals. The real time images are collected from four abnormal categories namely NPDR, CRVO, CNVM and CSR (Kavitha and Duraiswamy, 2011).

Pre-processing: The pre-processing step is a mandatory task in image classification since it helps in accurate feature extraction which ultimately results in high classification accuracy. The raw retinal images usually have very low contrast which is signified by the grouping of large peaks in a small area on the histogram

plot. The contrast of the retinal images is improved by histogram equalization which brings out details which are not clearly visible in the raw retinal images (Fig. 2 and 3). A better contrast is obtained by Gaussian filtering the resultant image. The second derivative Gaussian filtering is used since it distinguishes the background and foreground region besides enhancing the contrast of the image. These methods are applied separately to the red, green and blue components of the RGB colour values of the image (Anitha *et al.*, 2009b).

Feature extraction and selection: The four abnormal classes must be represented using relevant and significant features to classify the input images. The input image is clustered into four groups corresponding to background of the image, pupil, sclera and the abnormal region. The red, green and blue planes of the image are clustered individually using fuzzy C-means clustering algorithm and hence the total number of cluster centroids per image is 12. An extensive feature vector is formed with the cluster centroids of the training images from the four abnormal classes. The fuzzy approach is preferred over the hard segmentation methods since the regions of the input image are not always crisply defined. The extracted features are then fed to the classifier for classification (Anitha *et al.*, 2009a).

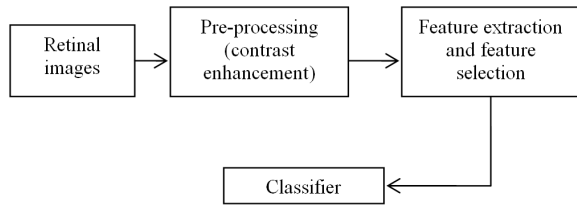

Fig. 2: Classification scheme for retinal images

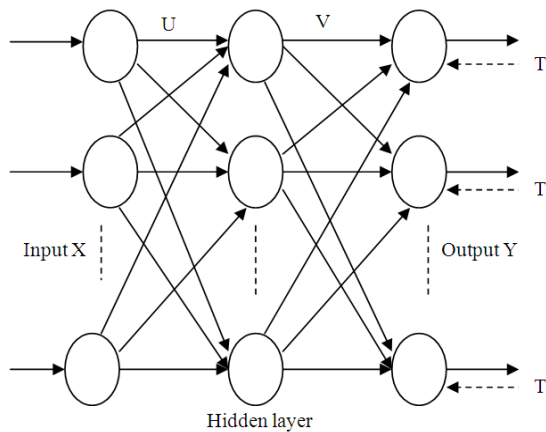

Fig. 3: Topology of BPN

For the automatic detection of hard exudates in retinal images, the following 24 features were extracted in the existing literature (Garcia *et al.*, 2007):

- Mean RGB values inside the region (1-3)
- Standard deviation of the RGB values inside the region (4-6)
- Mean RGB value around the region (7-9)
- Standard deviation of the RGB value around the region (10-12)
- RGB values of the region centroid (13-15)
- Region size (16)
- Region compactness (17)
- Region edge strength (18)
- Homogeneity of the region, measured in terms of the Shannon's entropy of the RGB values inside the region (19-21)
- Color difference of the RGB values(22-24)

Logistic Regression (LR) is a classifier-independent method commonly used for feature selection to avoid misclassification. It analyzes the relationship between a dichotomous dependent variable and several independent variables. Moreover, it does not need the data to comply with specific constraints. Assuming the possible values of the dependent variable are 0 and 1, LR can be modeled as:

$$\text{logit}(Y = 1) = \ln (P (Y = 1) / P (Y = 0)) = \alpha + \beta X$$

Where:

Y = The dependent variable

1 = The desired outcome

X = The independent variable vector

α and β = The parameters of the model to be identified by the maximum likelihood method

Classifiers: There are several kinds of classifiers are existing in the literature for classifying the abnormalities in retinal image data set.

Support Vector Machine (SVM) classification: SVM is a statistical learning method based on Structural Risk Minimization (SRM). In terms of the ability for generalization, SRM is superior to Empirical Risk Minimization (ERM) as employed by conventional neural networks. Consider a labeled two-class training set $\{x_i, y_i\}$, $i=1, \dots, l$, $x_i \in \mathbb{R}^d$, $y_i \in \{-1, 1\}$ is the associated "truth" (Zhang and Chutatape, 2005).

The separating hyperplane must satisfy the following constraints:

$$y_i[(w \cdot x_i) + b] \geq 1 - \xi_i, \xi_i \geq 0$$

Where:

- w = The weight vector
- b = The bias
- ξ_i = The slack variable

To find the optimal separating hyperplane, the following function should be minimized subjected to the above constraint:

$$\varphi(w) = \|\omega\|^2 / 2 + C \left(\sum_{i=1}^l \xi_i \right)$$

where, C is a parameter to be chosen by the user which controls the trade-off between maximizing the margin and minimizing the training error. A Larger C corresponds to assigning higher penalty to constraint violation. The classifier can be constructed as:

$$f(x) = \text{sgn}(w_0 \cdot x + b_0) = \text{sgn} \left(\sum_{\text{support vectors}} y_i \alpha_i^\circ (x_i \cdot x) + b_0 \right)$$

where, w_0 and b_0 denote the optimum values of the weight vector and bias respectively and α_i° is the Lagrange multiplier.

In case of a linear boundary being inappropriate, the SVM can map the input vector x into a high dimensional feature space by choosing a nonlinear mapping kernel (Xu and Luo, 2009). The optimal separating hyperplane in the feature space is given by:

$$f(x) = \text{sgn} \left(\sum_{i=1}^l y_i \alpha_i^\circ K(x_i, x) + b_0 \right)$$

where, K(x,y) is the kernel function. The following are some commonly used kernels.

Polynomial: $K(x,y) = ((x,y)+1)^d$

Gaussian radial basis function:

$$K(x,y) = \exp \left(-\|x-y\|^2 / 2\sigma^2 \right)$$

Back propagation neural network classification:

Back propagation network is the primarily used supervised artificial neural network. Before the training process begins, the selection of architecture plays a vital role in determining the classification accuracy. In this classification scheme, a three layer network is developed in general. An input vector and the corresponding desired output are considered first. The input is propagated forward through the network to compute the output vector. The output vector is

compared with the desired output and the errors are determined. The process is repeated until the errors being minimized (Anitha *et al.*, 2009a).

The architecture of the back propagation neural network used for the classification system consists of three layers namely input layer, hidden layer and output layer.

The input layer and the hidden layer neurons are interconnected by the set of weight vectors U and the hidden layer and the output layer neurons are interconnected by the weight matrix V. In addition to the input vector and output vector, the target vector T is given to the output layer neurons. Since Back Propagation Network operates in the supervised mode, the target vector is mandatory. During the training process, the difference between the output vector and the target vector is calculated and the weight values are updated based on the difference value.

Training algorithm: Training algorithms for feed forward networks use the gradient of the performance function to determine how to adjust the weights to minimize performance. The weight vectors are randomly initialized to trigger the training process. During training, the weights of the network are iteratively adjusted to minimize the network performance function in the sense of sum of squared error:

$$E = \sum (T-Y)^2 \text{ where } T \text{ is target vector, } Y \text{ is output vector.}$$

Such a learning algorithm uses the gradient of the performance function with a view to determine how to adjust the weights in order to minimize the error. The gradient is determined using a technique called back propagation, which involves performing computational backwards through the network. Back propagation learning updates the network weights in the direction where the performance function decreases most rapidly, the gradient being negative. Such an iterative process can be expressed as:

$$W_{k+1} = W_k - \alpha \cdot g_k$$

Where:

- W_k = Weight vector includes U and V
- α = Learning rate
- g_k = Current gradient

The gradient vector is the derivative of the error value with respect to the weights. Hence, the weight updation criterion of the BPN network is given by:

$$W_{k+1} = W_k - \alpha \cdot \frac{\partial E}{\partial W_k}$$

where, k = iteration counter E = difference between the target and the output values of the network

When the weight vectors U and V of the network remain constant for successive iterations, then the network is said to be stabilized. These weight vectors are the finalized vectors which represent the trained network. The testing images are then given as input to the trained network and the performance measures are analyzed.

Kohonen self-organizing map classification:

Kohonen Self-organizing Map is the unsupervised neural networks, which possesses the self-organizing property. Similar to statistical clustering algorithms, these kohonen networks are able to find the natural groupings from the training data set. As the training algorithm follows the winner take-all principle, these networks are also called as competitive learning networks.

The topology of the Kohonen Self-organizing Map is represented as a 2-Dimensional, one-layered output neural net. Each input node is connected to each output node. The dimension of the training patterns determines the number of input nodes. There is no particular geometrical relationship between the output nodes in the competitive learning networks. During the process of training, the input patterns are fed into the network sequentially. Output nodes represent the trained classes and the center of each class is stored in the connection weights between input and output nodes (Anitha *et al.*, 2009b).

Algorithm: The Kohonen Self-organizing Map uses the competitive learning rule for training the network. It uses the winner-take all principle in which a winner neuron is selected based on the performance metrics. The weight adjustment is performed only for the winner neuron and the weights of all other neurons remain unchanged. A detailed training algorithm is given below:

- Initialize weights w_{ij}
- While stopping condition is false, do the following steps
- For each output layer neurons J , compute $D(J) = \sum_i (w_{ij} - x_i)^2$
- Find Index J such that $D(J)$ is minimum
- Update the winner neurons weight using the rule $w_{ij}(\text{new}) = w_{ij}(\text{old}) + \alpha [x_i - w_{ij}(\text{old})]$ where x_i denotes the intensity values of input data set, α denotes the learning rate
- Test for stopping condition which is maximum number of iterations

Minimum distance classifier: Minimum Distance classifier is a decision theoretic approach for classification in which the classification is based on a decision function. The commonly used decision function is the Euclidean distance between the input and the class in the multi vector feature space. The input vector is allotted to the particular class for which the Euclidean distance is minimum (Anitha *et al.*, 2009a; 2009b; Nguyen *et al.*, 1997).

Algorithm: Suppose that each training class is represented by a mean vector given by:

$$m_j = 1 / N_j \sum_{x \in w_j} x \text{ for } j=1,2 \dots M$$

where, N_j is the number of training pattern vectors from class w_j .

Based on this any pattern x can be assigned to the class of its closest prototype by determining its proximity to each m_j . As Euclidean distance is the measure of proximity, then the distance to the prototype is given by:

$$D_j(x) = \|x - m_j\| \text{ for } j = 1,2 \dots M$$

The input training vector x is allotted to the class i if $D_i(x) < D_j(x)$ for $j = 1,2 \dots M, i \neq j$

RESULTS

This study reviews the existing approaches for detecting the abnormalities in retinal images with their merits and demerits. Abnormality in retinal images can be detected by support vector machine classification, back propagation neural network classification, Kohonen SOM classification and minimum distance classifier.

This study provides performance comparisons of the above techniques and suggested a proposed framework using cellular neural network.

DISCUSSION

The dataset used for the above mentioned three classification system is shown in the Table 1 (Anitha *et al.*, 2009a; 2009b).

The total number of abnormal images used is 205 among which 20 images from each class are used for training while the rest are used for testing the network.

The contrast of the raw retinal images can be enhanced using the second derivative Gaussian filter.

Table 1: Data set used for the classification system

Class	Training data	Testing data	Number of images per class
CNVM	20	32	52
CRVO	20	27	47
CSR	20	36	56
NPDR	20	30	50
Total abnormal images			205

Table 2: Performance comparisons of the above classifiers

Classifier	No. of testing images	Classification accuracy (%)
Minimum distance classifier	125	64
Kohonen network	125	88
BPN	125	92

Percentage of classification accuracy = (True Positive + True Negative)/No. of total subjects

These contrast enhanced images are applied to the Fuzzy c-means clustering algorithm and the cluster centroids for the three different planes of the input RGB image are obtained. Then the extracted features are used for the above mentioned three classification schemes. The performance comparisons of the various classifiers are given below Table 2 (Anitha *et al.*, 2009a; 2009b).

Proposed framework for our research: From the performance comparisons of the above classifiers, we are coming to know that Back Propagation Neural Network Classification offers more classifier accuracy. But still, there is some false positive and false negative can be detected by the classifier. To improve the classification accuracy further, we are proposing the new framework in which abnormality of retinal images can be detected by using Cellular Neural Network (CNN) based Classification as well as extracting some more additional features for classification (Matei and Matei, 2008).

Due to the parallel processing performed by the array structure in CNN, the performance of the classification will be improved further. The objectives of our proposed framework are:

- Construct a cellular neural network for classification of retina Images
- Develop the classification algorithm based on a cellular neural network
- Generate the classification rules based on the classification algorithm
- Based on the classification rules, abnormality can be detected in retina images

CONCLUSION

The eye diseases mainly contribute to blindness and often can't be remedied because the patients are

diagnosed too late with the diseases. In this study, we have discussed the overview of methodologies for detecting the abnormalities in retinal images which includes collection of retinal image data set, pre-processing techniques, feature extraction techniques and classification schemes. Also, we have shown the comparison of minimum distance classifier, kohonen SOM and BPN. The classifier accuracy can be improved further by using the cellular neural network for classification as well as extracting some more additional features for classification.

REFERENCES

Anitha, J., D. Selvathi and D.J. Hemanth, 2009a. Neural computing based abnormality detection in retinal optical images. Proceedings of the IEEE International Advance Computing Conference, Mar. 6-7, IEEE Xplore Press, Patiala, pp: 630-635. DOI: 10.1109/IADCC.2009.4809085

Anitha, J., C.K.S. Vijila, D.J. Hemanth and A. Ahsina, 2009b. Self organizing neural network based pathology classification in retinal images. Proceedings of the World Congress on Nature and Biologically Inspired Computing, Dec. 9-11, IEEE Xplore Press, Coimbatore, pp: 1457-1462. DOI: 10.1109/NABIC.2009.5393697

Garcia, M., R. Hornero, C.I. Sanchez, M.I. Lopez and A. Diez, 2007. Feature extraction and selection for the automatic detection of hard exudates in retinal images. Proceedings of the 29th Annual International Conference of the IEEE Engineering in Medicine and Biology Society, Aug. 22-26, IEEE Xplore Press, Lyon, pp: 4969-4972. DOI: 10.1109/IEMBS.2007.4353456

Goh, J., L. Tang, G. Saleh, L.A. Turk and Y. Fu *et al.*, 2009. Filtering normal retinal images for diabetic retinopathy screening using multiple classifiers. Proceedings of the 9th International Conference on Information Technology and Applications in Biomedicine, Nov. 4-7, IEEE Xplore Press, Larnaca, pp: 1-4. DOI: 10.1109/ITAB.2009.5394392

Hani, A.F.M., N.F. Ngah, T.M. George, L.I. Izhar and H. Nugroho *et al.*, 2010. Analysis of foveal avascular zone in colour fundus images for grading of diabetic retinopathy severity. Proceedings of the Annual International Conference of the IEEE Engineering in Medicine and Biology Society, Aug. 31-Sept. 4, IEEE Xplore Press, Buenos Aires, pp: 5632-5635. DOI: 10.1109/IEMBS.2010.5628041

- Kavitha, S. and K. Duraiswamy, 2011. Adaptive neuro-fuzzy inference system approach for the automatic screening of diabetic retinopathy in fundus images. *J. Comput. Sci.*, 7: 1020-1026. DOI: 10.3844/jcssp.2011.1020.1026
- Matei, D. and R. Matei, 2008. Detection of diabetic symptoms in retina images using analog algorithms. *World Acad. Sci. Eng. Technol.*, 45: 408-411.
- Nguyen, H., A. Roychoudhry and A. Shannon, 1997. Classification of diabetic retinopathy lesions from stereoscopic fundus images. Proceedings of the 19th Annual International Conference of the IEEE Engineering in Medicine and Biology Society, Oct. 30-Nov. 2, IEEE Xplore Press, Chicago, IL., pp: 426-428. DOI: 10.1109/IEMBS.1997.754569
- Nguyen, H.T., M. Butler, A. Roychoudhry, A.G. Shannon and J. Flack *et al.*, 1996. Classification of diabetic retinopathy using neural networks. Proceedings of the 18th Annual International Conference of the IEEE Engineering in Medicine and Biology Society, Oct. 31-Nov. 3, IEEE Xplore Press, Amsterdam, Netherlands, pp: 1548-1549. DOI: 10.1109/IEMBS.1996.647546
- Sanchez, C.I., R. Hornero, M.I. Lopez and J. Poza, 2004. Retinal image analysis to detect and quantify lesions associated with diabetic retinopathy. Proceedings of the 26th Annual International Conference of the IEEE Engineering in Medicine and Biology Society, Sept. 1-5, IEEE Xplore Press, San Francisco, CA., pp: 1624-1627. DOI: 10.1109/IEMBS.2004.1403492
- Sivakumar, R., G. Ravindran, M. Muthayya, S. Lakshminarayanan and C.U. Velmurughendran, 2003. Diabetic retinopathy classification. Proceedings of the TENCON Conference on Convergent Technologies for Asia-Pacific Region, Oct. 15-17, IEEE Xplore Press, pp: 205-208. DOI: 10.1109/TENCON.2003.1273315
- Xu, L. and S. Luo, 2009. Support vector machine based method for identifying hard exudates in retinal images. Proceedings of the IEEE Youth Conference on Information, Computing and Telecommunication, Sept. 20-21, IEEE Xplore Press, Beijing, pp: 138-140. DOI: 10.1109/YCICT.2009.5382409
- Zhang, X. and O. Chutatape, 2005. A SVM approach for detection of hemorrhages in background diabetic retinopathy. Proceedings of the IEEE International Joint Conference on Neural Networks, Jul. 31-Aug. 4, IEEE Xplore Press, Montreal, Que., pp: 2435-2440 DOI: 10.1109/IJCNN.2005.1556284