

Petri Net Based Spatio-temporal Relationships for Moving Objects

^{1,2}Yong-shan Liu and ^{1,3}Zhong-xiao Hao

¹College of Computer Engineering, Harbin University of Science and Technology, Heilongjiang
P.R.China 150008

²College of Information Engineering, Yanshan University, Qinhuangdao, Hebei, P.R.China 066004

³College of Computer Engineering, Harbin Institute of Technology, Heilongjiang, P.R.China 150008

Abstract: This study presents the spatio-temporal constraint relationships of moving objects by employing Petri Net technology. The spatial constraints of moving objects are first presented in this study based on the V_{41} ^[1] theory, then the temporal constraints for moving objects are presented by applying this theory to temporal aspect. With the proposing of Moving Object Petri Net (MOPN) and Spatial Constraint Petri Net (SCPN) in this study, the spatio-temporal constraint relationships of moving objects are presented.

Key words: Spatial-temporal database, moving object petri net, spatial constraint petri net

INTRODUCTION

Petri Net is an information stream model. Petri Net is also a critically defined mathematics object. It has a specially advantage of using Petri Net to describe dynamic action^[2]. Currently, there exist two division research on the spatio-temporal database of moving objects, namely temporal databases and spatial database that they have not been combined perfectly^[3]. The research is performed mainly about data model. The representational work was done by Erwig M and Wolfson O. The approach of Erwig M abstracted the moving objects to moving point (mpoint) and moving region(mregion), in which the mpoint and the mregion were observed from three dimensions(two spatial dimensions and one temporal dimension). This made them from entity to model and become abstracted data type^[3]. This model is compatible with data models of relationship database, object-oriented database and other DBMS. Wolfson's studies mainly proposed the concept of dynamic attribute that denotes the attribute is temporal continuous, the Future Temporal Logic (FTL)^[4] language and Moving Object Spatio-Temporal (MOST)^[4] model. The spatio-temporal relationships are discussed based on multimedia data in References^[5, 6]. These researches are all performed from particular aspect to express moving objects and lack of integrity in semantic expression of moving objects. In this study, the spatio-temporal constraints of moving objects are presented by using the Petri net, which is an effective tool to describe moving objects as the first step.

Spatial constraints of moving objects: In spatial database, spatial objects are abstracted into three basic types, point, line and region. Because line reflects the

moving of object, and point can be treated as a special case of region when the position of moving object is expressed, in this study, the positions of moving objects are expressed by employing region.

According to the topological relationships theory of spatial database^[1], the spatial targets are constituted of point sets. A 4-tuples is constituted of the intersection of boundaries and inners of two point sets. Let A, B be the spatial targets and then the 4-tuples is defined as:

$$R_{41}(A,B)= \begin{bmatrix} \partial A \cap \partial B & \partial A \cap B^0 \\ A^0 \cap \partial B & A^0 \cap B^0 \end{bmatrix} \quad (1)$$

Let $\partial A, A^0$ be the boundary and inner of target A and $\partial B, B^0$ be the boundary and interior of target B. In this 4-tuples, there will exist $2^4=16$ cases and 16 possible relations. According to the fact, 8 temporal relationships cases will exist except 8 cases that can not exist. Thus, the spatial relationships of moving objects can be obtained as shown in Table 1.

Temporal constraints: Several definitions are given before the temporal constraints of moving objects are described:

Definition 1: Let I be a point set in Euclidean Space IR (one dimension real axis), then I^0 , the interior of I, be the maximum open set contained by I. I_c , the closure of I, be the minimum closed set contained by I, then ∂I , the boundary of I equals $I_c - I^0$.

Table 1: The spatial relationships of two moving objects







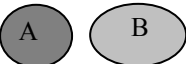

Cutline	Semantic explain	Marked as
	A and B are disjointed (disjoint(A,B))	Sd
	A and B are met (meet(A,B))	Sm
	A and B are equal (equal(A,B))	Se
	A and B are overlapped (overlap(A,B))	So
	A is inside B and their boundaries are not intersected (inside(A,B))	Si
	A contains B, and their boundaries are not intersected (contain(A,B))	Sct
	A is covered by B and their boundaries are intersected. (coverby(A,B))	Scb
	A covers B and their boundaries are intersected (cover(A,B))	Sc

Table 2: The topological relationships between two temporal intervals





Cutline	Predication	Semantic Explanation
	$T_{disjoint}$	I and J exist disjointed
	T_{meet}	I and J meet at a point
	$T_{overlap}$	I and J are overlapped
	T_{cover}	I and J have the same start time
	$T_{coveredby}$	I and J have the same end time
	T_{equal}	I and J exist at the same time
	T_{inside}	I exists during J's existence
	$T_{contain}$	J exists when I's existence

Table 3: Spatial constraints implied by temporal constraints

Temporal Constraints	Spatial Constraints Implied
$Td(A,B)$	$(Us(A,B),[Ms(A),Me(A)]) \wedge (Ems(A,x),[Me(A)+1,Me(\delta)]) \wedge (Ems(A,x),[Me(A)+1,Me(\delta)]) \wedge (Ems(B,x),[Me(B)+1,Me(\delta)]) \wedge (Us(B,A),[Me(\delta)+1,Me(B)])$
$Tm(A,B)$	$(Us(A,B),[Ms(A),Me(A)]) \wedge (Us(A,B),[Me(A)+1,Me(B)])$
$To(A,B)$	$(Us(A,B),[Ms(\delta),Me(\delta)]) \wedge (Sr(A,B),[Me(\delta)+1,Me(A)]) \wedge (Us(B,A), [Me(A) + 1, Me(B)])$
$Tcb(A,B)$	$(Us(A,B),[Ms(A),Me(\delta)]) \wedge (Sr(A,B),[Me(\delta)+1,Me(B)])$
$Tct(A,B)$	$(Us(A,B),[Ms(\delta),Me(\delta)]) \wedge (Sr(A,B),[Me(\delta)+1,Me(B)]) \wedge (Us(A,B),[Me(B)+1,Me(A)])$
$Tc(A,B)$	$(Sr(A,B),[Ms(A),Me(A)]) \wedge (Us(B,A),[Me(A)+1,Me(B)])$
$Ti(A,B)$	$(Sr(A,B),[Ms(B),Me(B)]) \wedge (Us(A,B),[Me(B)+1,Me(A)])$
$Te(A,B)$	$(Sr(A,B),[Ms(A),Me(A)])$

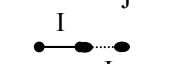
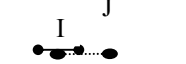
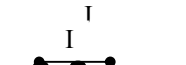
Definition 2: To simulate temporal interval $I(=[T_b, T_e])$ as a point set in Euclidean Space IR , I^0 , the interior of temporal interval, is to be the total temporal course

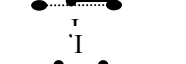
except the start time and the end time ($I^0=I-\{T_b, T_e\}$), ∂I , the boundary of temporal interval I , is to be the start and end time of $I(\partial I=\{T_b, T_e\})$.

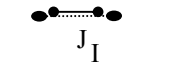
The temporal topological relationships are given as below:

Let I, J be two different temporal targets(temporal interval) in temporal universal set, then the temporal topological relationships $T_{Top}(I,J)$ between I, J based on point set theory can be described as:

$$T_{Top}(I,J)= \begin{bmatrix} \partial I \cap \partial J & \partial I \cap \partial J^0 \\ I^0 \cap \partial J & I^0 \cap J^0 \end{bmatrix} \quad (2)$$

There are $2^4=16$ cases and 16 possible relationships in this 4-tuples,. According to the fact, 8 temporal relationship cases will be existed after discarding 8 cases that can not exist. The 8 left temporal relations are described by Table 2.

According to the above discussion, the temporal relationships between the two moving objects (denote by A and B) can be obtained:

- * Tdisjoint(A,B): denotes that the two moving objects are disjointed on temporal(mark as Td).
- * Tmeet(A,B): denotes that the two moving objects are met on temporal(mark as Tm).
- * Toverlap(A,B): denotes that the two moving objects are overlapped on temporal(mark as To).
- * Tcover(A,B): denotes that the two moving objects have the same start time on temporal(mark as Tc).
- * Tcoverby(A,B): denotes that the two moving objects have the same end time on temporal(mark as Tcb).
- * Tequal(A,B): denotes that the two moving objects are equal on temporal(mark as Te).
- * Tinside(A,B): denote that the moving object A is inside moving object B on temporal(mark as Ti).
- * Tcontain(A,B): denote that the moving object A contains moving object B on temporal(mark as Tct).

We denote the start time of moving object in one state by $Ms(Mo)$, denotethe end time of moving object in one state by $Me(Mo)$.

Spatial relationships of moving objects: The spatial relationship of two moving objects is not static, it changes over time, in another word, it is constrained by dynamic space.

Definition 3: The special relationships of moving objects are described by 2-tuples(So,I), in which So is the static position relationships and I is the durative time. For example $(disjoint(A,B),[t_1,t_2])$ denotes that objects A and B are disjointed during the period of time t_1 to time t_2 .

Model of spatio-temporal constrained moving objects: The model is constituted of two graphs. One is called moving object Petri net, the other one is called

spatial constrained Petri net. The formalized description of the two graphs are described as follows:

Definition 4: a Moving Object Petri Net(MOPN) is a 7-tuples(S,T,F,R_T,S_R,S_I,M), in which,

$S=\{p_1,p_2,\dots,p_n\}$ is a finite place set.

$T=\{t_1,t_2,\dots,t_m\}$ is a finite transition set.

$F:\{T \times S\} \rightarrow \{S \times T\}$ is a directed edge set.

$R_T:S \rightarrow R$ is the map from place set to real set (duration).

$S_R:S \rightarrow \{reg_1,reg_2,\dots,reg_k\}$ is the map from place set to region.

$S_I:S \rightarrow \{i_1, i_2,\dots,i_k\}$ is the map from place set to information resource set.

$M:S \rightarrow I'$ ($I'=\{0,1, \dots\}$) is to assign initial marking to the places in the net.

For a given transition, there exists a unblocked marking in the input places, then it be initialized that make the marking transit from input places to every output places. In the associate time, when the marking is added to every output places, the markings in the places are blocked.

The places in MOPN describe the status of a moving object, that is, the persist time of moving object (R_T), region (S_R) and information source(S_I).

Definition 5: A Spatial Constraint Petri Net (SCPN) is a 6-tuples (S,T,F,R_T,MO,M_{SC}), in which,

$S=\{p_1,p_2,\dots,p_n\}$ is a finite place set

$T=\{t_1,t_2,\dots,t_m\}$ is a finite transition set

$F:\{T \times S\} \rightarrow \{S \times T\}$ is a directed edge set

$R_T:S \rightarrow R$ is the map from place set to real set (duration)

$MO:P \rightarrow 2^{MO}$ is the map from place set to moving object set

M_{SC} :is the map from place set to the steady spatial constraints of objects that associate with places.

The places in SCPN describes the status which constitutes moving object set , that is, the object associated with the places (MO), the position relationships of the objects(M_{SC}) and the duration time of the position relationships(R_T).

Definition 6: The graph of the spatio-temporal moving object is a dual(G_1,G_2), where G_1 is a MOPN and G_2 is a SCPN.

The relationship between MOPN and SCPN are discussed in Fig. 1, partially shows part of the corresponding relationships (δ denote delay object). The different between MOPN and SCPN can be seen from Fig. 1.

Transitions: MOPN denotes the join relationship of the moving objects at a position, where δ denotes delay object.

The transition in SCPN denote the change of the spatial position constraint relationship that the moving object shows.

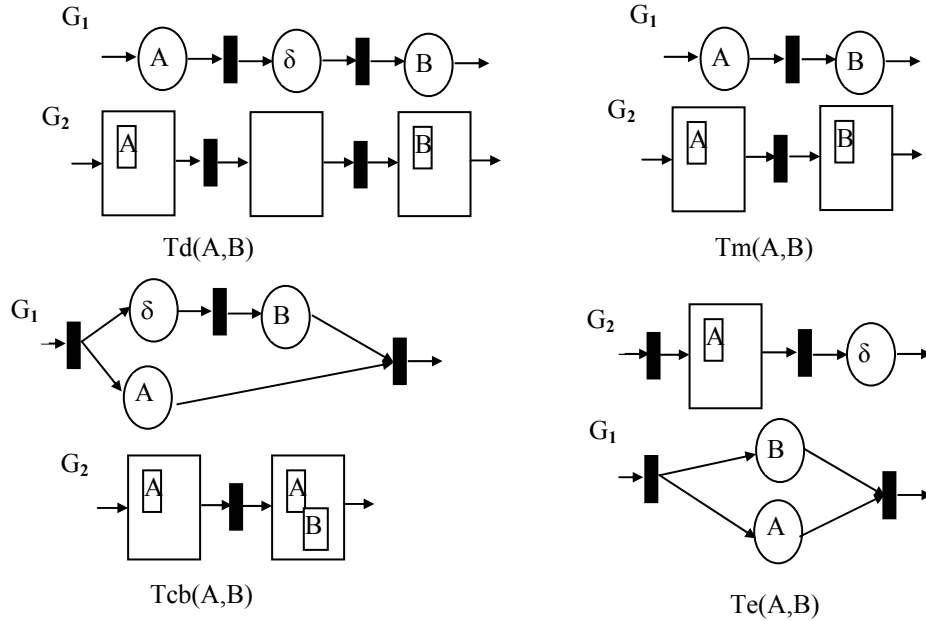

Fig. 1: Part of the corresponding relationships (δ denote delay object)

Table 4: Temporal constraints implied by spatial constraints

Spatial Constraints	Temporal Constraints Implied
$Se(A,B), Sct(A,B), Sm(A,B)$	$Tm(A,B), To(A,B), Tcb(A,B)$
$Scb(A,B), Sc(A,B), So(A,B), Si(A,B)$	$Tct(A,B), Tc(A,B), Te(A,B)$
$Sd(A,B)$	$Tm(A,B), To(A,B), Tcb(A,B), Tct(A,B), Tc(A,B), Te(A,B), Td(A,B)$

Places: The places in MOPN is corresponding to a moving object at a position.

The places in SCPN is corresponding to a group of moving objects at a position.

Temporal Information: The period of time associated by a places in MOPN denotes the moving object existing in this period. The period of time associated by a places in SCPN denotes that the special position relationships of objects relationship keep unchanged in the period.

Spatial information: The places in MOPN describes the region expression that is associated with it.

The places in SCPN describes the spatial position relationships of several moving objects, this relationship doesn't change until the next place.

Spatio-temporal constraint relationships: Additional constraints are introduced before we discuss the spatio-temporal constraint relationship.

Empty constraint: $Ems(Mo_1, Mo_2)$:no spatial constraint relationship between object Mo_1 and object Mo_2 .

$Emt(Mo_1, Mo_2)$: no temporal constraint relationship between object Mo_1 and object Mo_2 .

Mismatched constraint: $Us(Mo_1, Mo_2)$:Only object Mo_1 is described in spatial model, that is, Mo_2 is not included in the spatial constraint.

$Ut(Mo_1, Mo_2)$:Only object Mo_1 is described in temporal model, that is, Mo_2 is not included in the temporal constraint.

For example, $(Ems(A_1, B_2), I)$ denotes that in period I, object A_1 and object B_2 have no spatial constraints. $(Ut(A, B), I)$ denotes that there is no temporal constraint include B in period I.

According to the graph of the spatio-temporal constraints, the spatio-temporal constraint relationships are given. The spatio-temporal constraints consist of two cases. One is the contained spatial constraints resolved by the temporal constraints. The other one is the contained temporal constraints resolved by the spatial constraints (Sr denotes any kind of spatial constraint in Table 3).

* Spatial constraints contained by temporal constraints

Let's see that $Te(A, B)$ contains $(Sr(A, B), [Ms(A), Me(A)])$. $Te(A, B)$ denotes that the temporal period of two moving objects which exist in a status is equal.

Let's see $(Sd(A, B), [Ms(A), Me(A)])$, which denotes that in the period of $[[Ms(A), Me(A)]$ (or $[Ms(B), Me(B)], for [Ms(A), Me(A)] = Ms(B), Me(B))$), two moving objects' spatial position are disjointed, namely that A and B are at its own position in the same period. This is concordant with the fact. So, $Te(A, B)$ can be considered to contain $(Sd(A, B), [Ms(A), Me(A)])$.

Similarly, $Te(A,B)$ contains $(Sm(A,B), [Ms(A), Me(A)])$; $Te(A,B)$ contains $(Se(A,B), [Ms(A), Me(A)])$; $Te(A,B)$ contains $(So(A,B), [Ms(A), Me(A)])$; $Te(A,B)$ contains $(Si(A,B), [Ms(A), Me(A)])$; $Te(A,B)$ contains $(Sct(A,B), [Ms(A), Me(A)])$; $Te(A,B)$ contains $(Scb(A,B), [Ms(A), Me(A)])$; $Te(A,B)$ contains $(Sc(A,B), [Ms(A), Me(A)])$; There exists $Te(A,B)$ contains $(Sr(A,B), [Ms(A), Me(A)])$ exists. The other relationships can be obtained by using the same method.

* Temporal constraints contained by spatial constraints

Let's see that $Se(A,B)$ contains $Tm(A,B), To(A,B), Tcb(A,B)$. If let A and B be totally equal in spatial, the temporal sequences will follow below: first A and B are equal in spatial at the same time, that is, $Tm(A,B)$ exists, second, A and B persist for a certain time at the same status, that is, $To(A,B)$ exists; finally, A and B are separated, that is, $Tcb(A,B)$ exists. So $Se(A,B)$ contains $Tm(A,B), To(A,B), Tcb(A,B)$. The other contained relationship can be obtained by employing the same approach.

CONCLUSION

Spatial-temporal database is a new and developing subject that has many problems to be resolved. The spatio-temporal constraint relationships of moving objects are proposed by employing Petri Net technology in this study, but there exist many research works to do. For example, if the $V_{91}^{[7]}$ technology and the semantic of temporal direction relationship are considered^[8], what the constraint relationship will be? And how to build the data model based on Petri Net? In order to answer these questions, a further study is necessary.

REFERENCES

1. Egenhofer, M.J. and J.R. Herring, 1990. A mathematical framework for the definition of topological relationships. In: Proc. 4th Intl. Symp. Spatial Data Handling, pp: 803-813.
2. Yuan Congyi, 1998. Theory of Petri net. Beijing. Public House of Electric Industry.
3. Erwig, M., R.H. Güting, M. Schneider and M. Vazirgiannis, 1999. Spatio-temporal data types: An approach to modeling and querying moving objects in database. GeoInfo, pp: 269-296.
4. Wolfson, O., *et al.*, 1998. Moving Objects Database: Issues and Solutions. In: Proc. 10th Intl. Conf. Scientific and Statistical Database Management (SSDBM98). Capri (Italy), pp: 111-122.
5. Kwon, Y.M., E. Feerari and E. Bertino, 1999. Modeling spatio-temporal constraints for multimedia objects. Data and Knowledge Engineering, 30: 217-238.
6. Little, T.D.C. and A. Ghafoor, 1993. Interval-based conceptual models for time dependent multimedia data. IEEE Trans. Knowledge and Data Engineering, 5: 1368-1382.
7. Chen Jun, Li Chenming, Li Zhilin and C.M. Gold, 2000. A Voronoi-based 9-intersection model for spatia relation. Int. J. of GIS, 15: 201-220.
8. Edwards, G., P. Gagnon, Y. Bedard and P. Casault, 1993. Spatio-temporal topology and causal mechanisms in time-integrated GIS: From conceptual model to implementation strategies., pp: 842-857.