

Gaussian Dispersion Model to Estimate the Dispersion of Particulate Matters (Pm_{2.5}) and Sulfur Dioxide (SO₂) Concentrations on Tribal Land, Oklahoma

Dejene Alemayehu and Francine Hackett

Department of Kaw Nation Environmental, Kaw City, OK 74641, USA

Article history

Received: 15-04-2015

Revised: 11-05-2015

Accepted: 20-11-2015

Corresponding author:

Dejene Alemayehu

Department of Kaw Nation

Environmental, Kaw City, OK

74641, USA

Email: dejene@kawnation.com

Abstract: Air quality in most parts of Kay County is good and unlikely to cause major health problems. However, Kaw Nation wants to know if the concentration of Particulate matters (PM_{2.5}) and Sulfur dioxide (SO₂) released from power plants, refinery and carbon black plant in Oklahoma reaches the Tribal land at Kanza Travel Plaza, Braman, Kay Co. Oklahoma. Kanza Travel Plaza is located in the north central Oklahoma 22 miles Northwest of Ponca City at a latitude of 36.9395 degrees North and longitude of -97.3453 degrees West. In order to estimate the concentration of PM_{2.5} and SO₂ that reaches the Tribal land, Kaw Nation run the U.S. Environmental Protection Agency regulatory air quality model called AERMOD (Version 15181). AERMOD is a steady state plume model that measures dispersion of gases and particulate matters from the source to the point of impact within source radius. The study sites are flat and rural conditions with less complex terrain. Meteorological data representative of the study area was preprocessed using AERMET program. AERMET prepares hourly surface data and upper air data. The hourly surface data was obtained from Station #3965 (Stillwater Regional), while the upper air data was obtained from Station #3948 (Norman). The Building parameters such as height and length were processed using the building profile called BPIB. To calculate the concentration of PM_{2.5} and SO₂ air pollutants released from the coal power plant the Gaussian air modeling (AERMOD) used Control, Source, Receptor, Metrological and Output pathways. The AERMOD result indicates at least 19-26% of PM_{2.5} and SO₂ released from the stacks of the power plants, refinery and carbon black plant into the atmosphere reaches the Tribal land. Based on the Gaussian air modeling (AERMOD and BAM 1020 Continuous Air monitor) less than 12 µg/m³ of pollutant has been captured that falls within the attainment zone as per the National Ambient Air Quality Standards (NAAQS).

Keywords: Gaussian Dispersion Model, PM_{2.5}, SO₂, AERMOD Air Quality Model

Introduction

The Kaw Nation Environmental Department in 2014 conducted an emission inventory of some selected stationary or point sources for criteria pollutants. The emission inventory of the criteria pollutants measured was particulate matter, sulfur dioxide, nitrogen dioxide, carbon monoxide and ozone.

Furthermore, the Kaw Nation wants to determine how much of these pollutants actually fall on Tribal

land. In support of this, the Kaw Nation decided to run a U.S. EPA regulatory dispersion model called AERMOD. AERMOD is a steady state plume model that calculates the dispersion and concentration of pollutants within the range of 80 km (about 50 miles) radius from the industrial sources to the point of impact (U.S. EPA 2004).

In AERMOD, the meteorological conditions were assumed to be steady and horizontally homogeneous (Cimorelli *et al.*, 2004). Dispersion air modeling is an

important tool to predict transport, diffusion and dispersion of atmospheric pollutants (Lathe and Shamugam, 2010). A dispersion model can predict concentration of pollutants, from the site of generation to a site of deposition based on emissions and meteorological data available.

Pollutants enter the atmosphere in different ways; one way is by PM_{2.5} and SO₂ released from stacks by a power plant mixed with atmosphere leaving out of stacks. These emitted gases have momentum as they enter the atmosphere creating gases that are heated and warmer than the outside air making it less dense and buoyant forming plumes. The wind and temperatures largely determine the rise of the plumes.

The Gaussian dispersion model that is undertaken in determining the transport and deposition of PM_{2.5} and SO₂ and other criteria pollutants from a coal fired thermal power plant was based on the following equation (Masters, 1997; MacDonald, 2003).

$$C(x, y, z) = \frac{Q}{2\pi u \sigma_y \sigma_z} e^{-\frac{y^2}{2\sigma_y^2}} \left(e^{-\frac{(z+H)^2}{2\sigma_z^2}} + e^{-\frac{(z-H)^2}{2\sigma_z^2}} \right)$$

Fig. 1. Gaussian dispersion model equation

Where:

- $C(x, y, z)$ = Concentration at ground level at the point (x, y, z) , $\mu\text{g}/\text{m}^3$
- x = Distance directly downwind, m

- y = Horizontal distance from the plume centerline, m
- Q = Emission rate of pollutants, g/s
- H = Effective stack height, m ($H = h + \Delta h$)
- h = Actual stack height and Δh = plume rise
- μ_H = Average wind speed at the effective height of the stack, m/s
- σ_y = Horizontal dispersion coefficient (standard deviation), m
- σ_z = Vertical dispersion coefficient (standard deviation), m

Model

The application of Gaussian dispersion model requires knowledge of emission release rate, atmospheric turbulence, wind speed, dispersion coefficient, effective mixing height, etc. The model assumes an ideal steady state of constant meteorological condition, idealized plume geometry and uniform terrain (U.S. EPA, 2004).

The wind speed, wind direction, relative humidity and cloud cover data was used for the prediction of the Gaussian model (Fig. 3).

Input Parameter

The meteorological data in Kay County was acquired from the Stillwater Regional in Oklahoma. The meteorological data included wind speed, frequency of distribution, average wind speed and direction of wind speed.

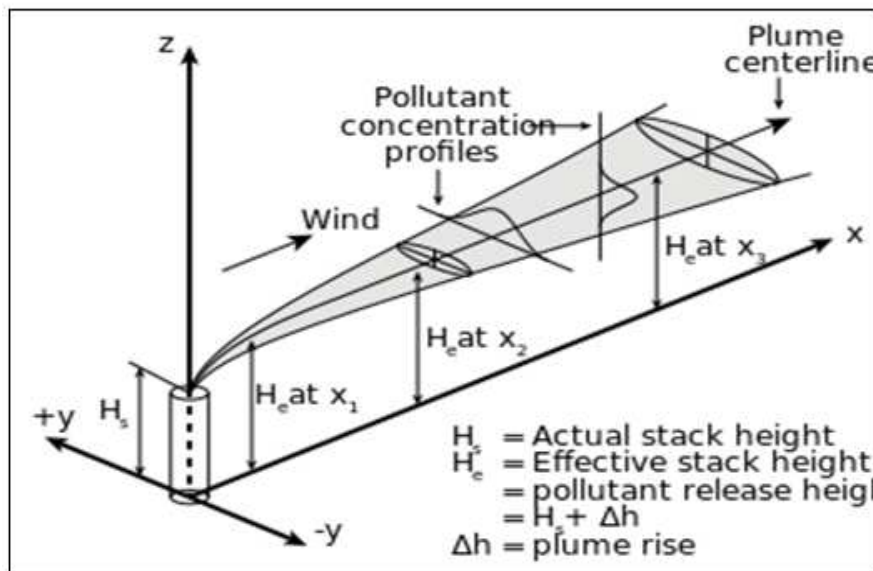

Fig. 2. Gaussian distributions in the horizontal and vertical directions (Source: Masters, 1977)

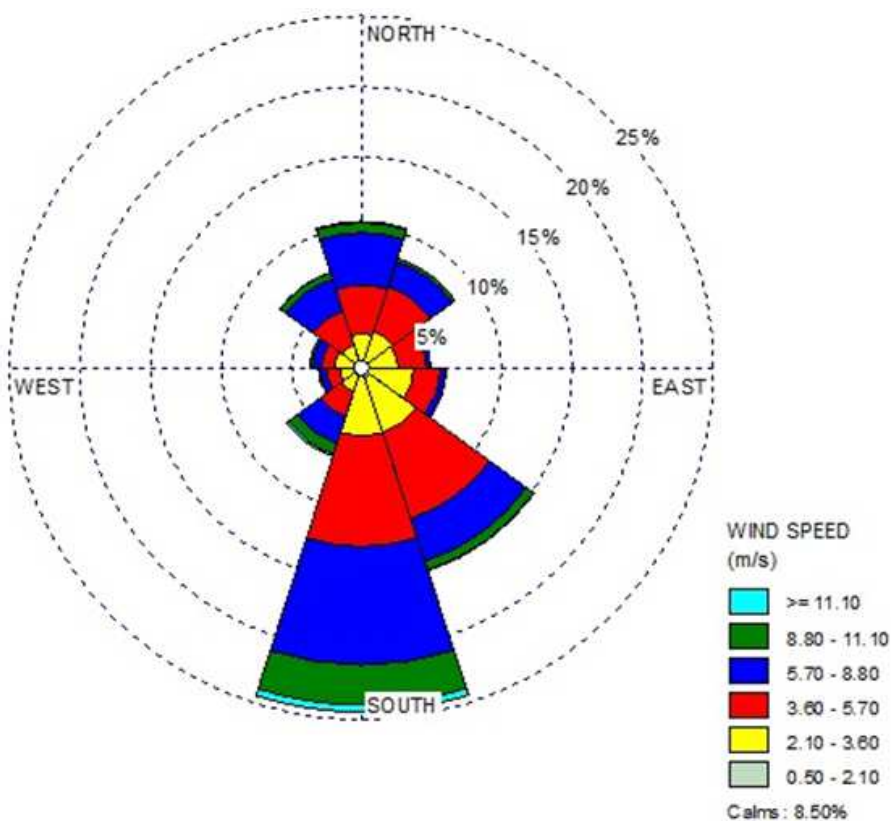

Fig. 3. Stillwater regional data

Methodology

Emission Inventory of Air Quality

The Kaw Nation Environmental Department (KNED) has collected air quality emission data from selected stationary sources within Noble County, Kay County of Oklahoma and from Oklahoma Department of Environmental Quality (ODEQ). KNED has specifically collected emission of Criteria pollutants from:

- Power plants
- Refineries and
- Carbon Black Plants

The emission criteria pollutants were run through Tribal Emission Inventory Software Solution (TEISS) model. The model was developed by (LES, 1996-2015). The model runs emission of stationary sources, mobile and biogenic sources with basic principles of emission factors developed by U.S. EPA. The model analyze the data based on:

$$E = A \times EF (1 - ER / 100)$$

Where:

E = emission

A = Activity

EF = Emission factor

ER = Efficiency Reduction Percentage

Dispersion of Air Quality

Criteria pollutants, mainly the Particulate matter and Sulfur dioxide are released from power plants, refineries and carbon black plants into the atmosphere. Kaw Nation wants to know how much of these pollutants fall on Tribal Land. Kaw Nation assumed the Air Quality Dispersion Modeling Tool called AERMOD (Version 15181) would help to predict the transport and dispersion of the criteria pollutants from the site of generation to a site of deposition through available metrological data and determine the concentration of pollutants at the required downwind receptor location.

In order to run the air quality dispersion model (AERMOD) meteorological data representatives of the study area were pre-processed using AERMET program. The AERMET program is a meteorological process which prepares hourly surface data and upper air data. The hourly surface air data was obtained from Stillwater

Regional, while the upper air data was obtained from Norman in Oklahoma. The hourly surface observation data included wind speed, wind direction, day bulb temperature and cloud cover. While the upper air data included latitude, longitude, site measurements (albedo, bower ratio and surface roughness).

Operation of the Model

A base map with reference point of latitude and longitude, WGS84 datum and a radius of 80 km (about 50 miles) was defined as a starting point. Then the building parameters such as height and length were specified and processed using building profile in a program called BPIP. Once the BPIP was run targeting the building downwash, data was inputted in 5 pathways. These were:

Control Pathway

In the control pathways dispersion options, pollutant types and averaging time were modeled. The types of pollutant modeled were particulate matters and sulfur dioxide. The averaging time options panel was 1-hr, 24-hr and annual average time was used. The dispersion coefficient was rural in the terrain height option parameters.

Source Pathway

In the source pathway modelers specify source of emission for particulate matter, sulfur dioxide and particulate matters were from coal fired power plant, refinery and carbon black plant. In this study the base elevation, release height, emission rate, gas exit temperature and gas exit velocity were identified (Table 1).

Receptor Pathway

Specifies the receptor location, including the number and type of receptors (Uniform Cartesian Grid) in all the project area.

Meteorology Pathway

Contains the information on the AERMET processed hourly surface data and upper air data files. The AERMET program processed these met data in 3 steps. The output files passed to the Met Pathway are the Surface File (SFC), Profile File (PFL) and surface base elevation (MSL). AERMET also prepared data for the Wind Rose plots presented in Fig. 3 (Stillwater Regional Airport).

Output Pathway

In this output pathways output options such as contour plot files and tabular options were specified.

Results

Air Quality Monitoring

The Kaw Nation Environmental Department wants to measure the concentration of criteria pollutants mainly PM_{2.5} and SO₂, released from a Coal fired power plants, refineries, carbon black plants on its Tribal land in Braman, Oklahoma. In order to measure the concentration of PM_{2.5}, the Kaw Nation installed a BAM 1020 Continuous Monitor at the Kanza Travel Plaza, Braman, Oklahoma. This monitoring site is located at latitude of 36° 54' 24.11 N and longitude of 97° 34' 23.00 W. The concentration of PM_{2.5} were captured every 5 min, 1 h and 24 h. The data loggers are transmitted to the Kaw Nation Environmental Department, located in Kaw City for further analysis and validation. Finally, Calibrated data were sent to U.S. EPA Central Data Exchange (CDX) database for public use.

Discussion

The Gaussian dispersion model as depicted in Figure 1 is the concentration of pollutants directly proportional to the emission rate, stack height, horizontal dispersion, atmospheric turbulence, wind speed and wind direction. Figure 2 reveals that the concentration is influenced by vertical as well as horizontal direction. As observed in Fig. 3, the wind was blowing from south of the plant to the north, driving the pollutants to the Kanza Travel Plaza monitoring site.

As indicated in Table 1, the stack height is 152.44 and 6.1 m diameter with emission rate 407.73 lb h⁻¹ respectively for the power plant. The stack heights for the refinery were between 16.79-52.43 and 0.9-3.0 m diameter with emission rate 6.0-25 lb h⁻¹ respectively. The stack heights for the carbon black plant were between 45.72-64.92 and 2.1-3.5 m diameter with emission rate 123.44-202.57 lb h⁻¹ respectively. In the power plant the exit temperature was 402 Kelvin degrees and the hydrocarbon refinery the exit temperature was between 493-778 Kelvin degrees, while the carbon black plant exit temperature was about 1200 Kelvin degrees. The dispersion of the criteria pollutants concentration in the power plant the refinery and the carbon black plant decreased outwards from the point of origin to the point of impact (Fig. 5a through 7b) due to the terrain height, horizontal distance, stack height, temperature of the plume, wind direction, wind speed, turbulence and other metrological parameters (ODEQ, 2011).

Based on the data collected from Oklahoma Department of Environmental Quality, the results for the power plant in Noble County emits about 16

$\mu\text{g}/\text{m}^3$ of $\text{PM}_{2.5}$ (Fig. 5a) and $205 \mu\text{g}/\text{m}^3$ of SO_2 (Fig. 5b) into the atmosphere at stack height of 152 m. The refinery in Kay County emits about $8 \mu\text{g}/\text{m}^3$ of $\text{PM}_{2.5}$ (Fig. 6a) and $259 \mu\text{g}/\text{m}^3$ of SO_2 (Fig. 6b) into the

atmosphere. On the other hand, the Carbon black plant in Kay County emits about $5 \mu\text{g}/\text{m}^3$ of $\text{PM}_{2.5}$ (Fig. 7a) and $223 \mu\text{g}/\text{m}^3$ of SO_2 (Fig. 7b) to the atmosphere every year, data results shown in Table 2.

Power Plant

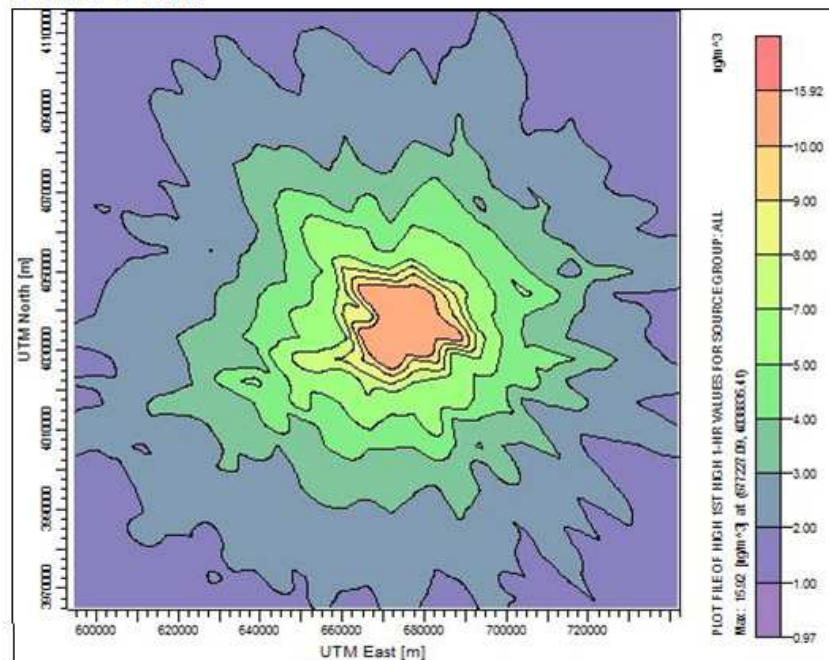

(a)

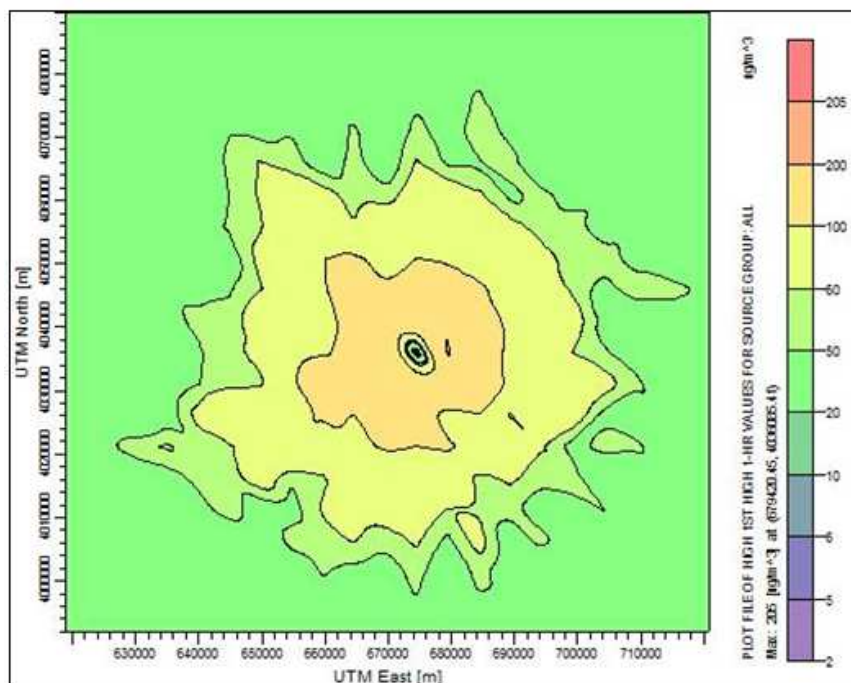

(b)

Fig. 5. (a) Dispersion for $\text{PM}_{2.5}$ from Power Plant (b) Dispersion for SO_2 from Power Plant

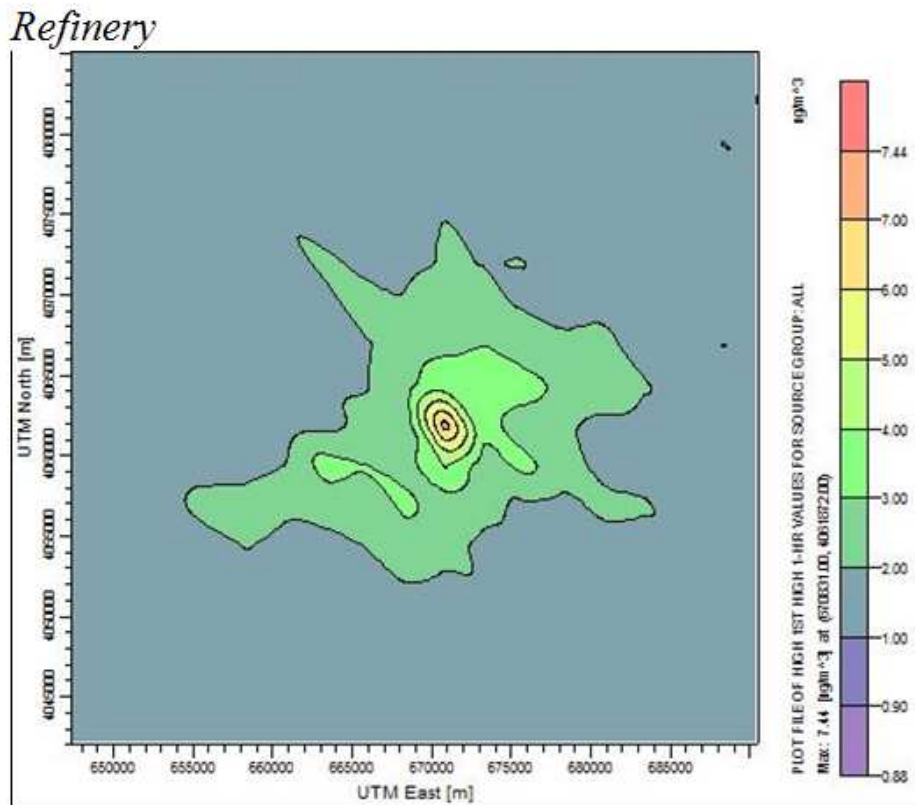

(a)

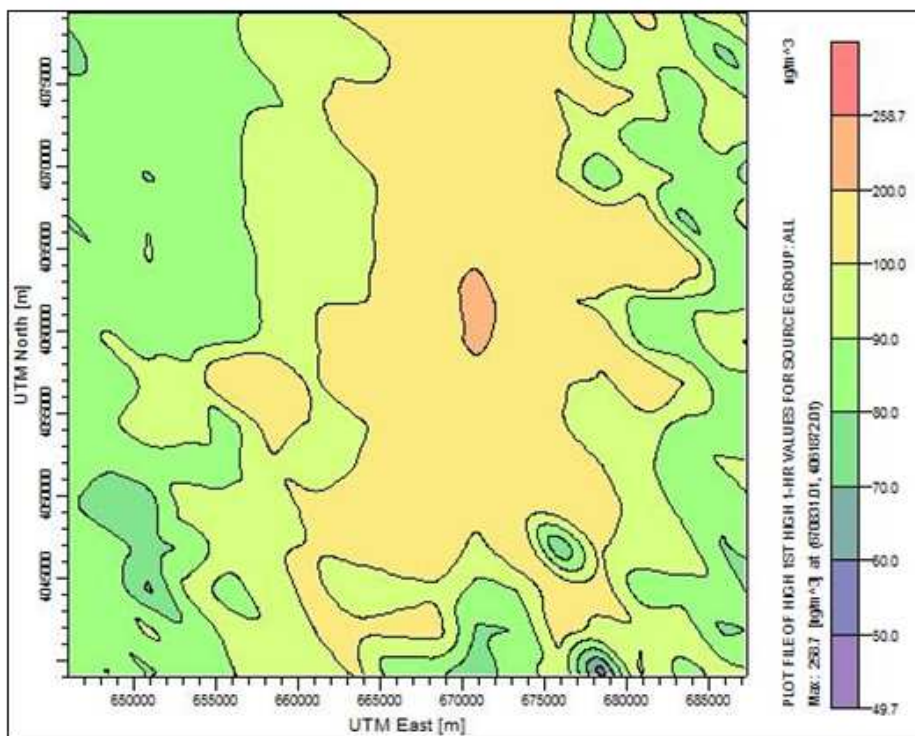

(b)

Fig. 6. (a) Dispersion of PM_{2.5} from Refinery (b) Dispersion of SO₂ from Refinery

Carbon Black

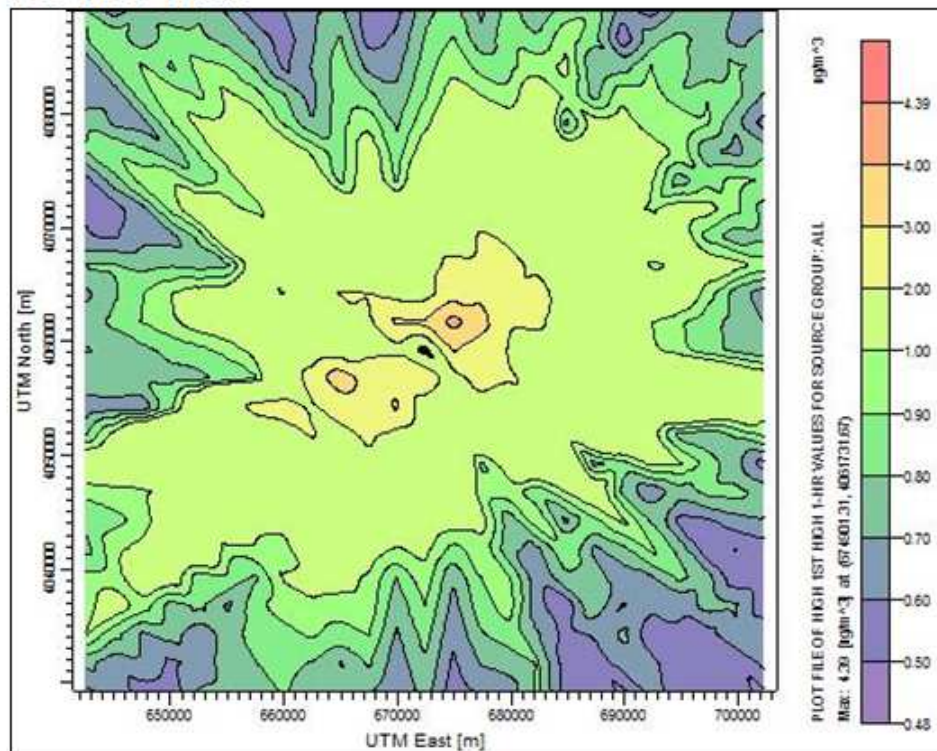

(a)

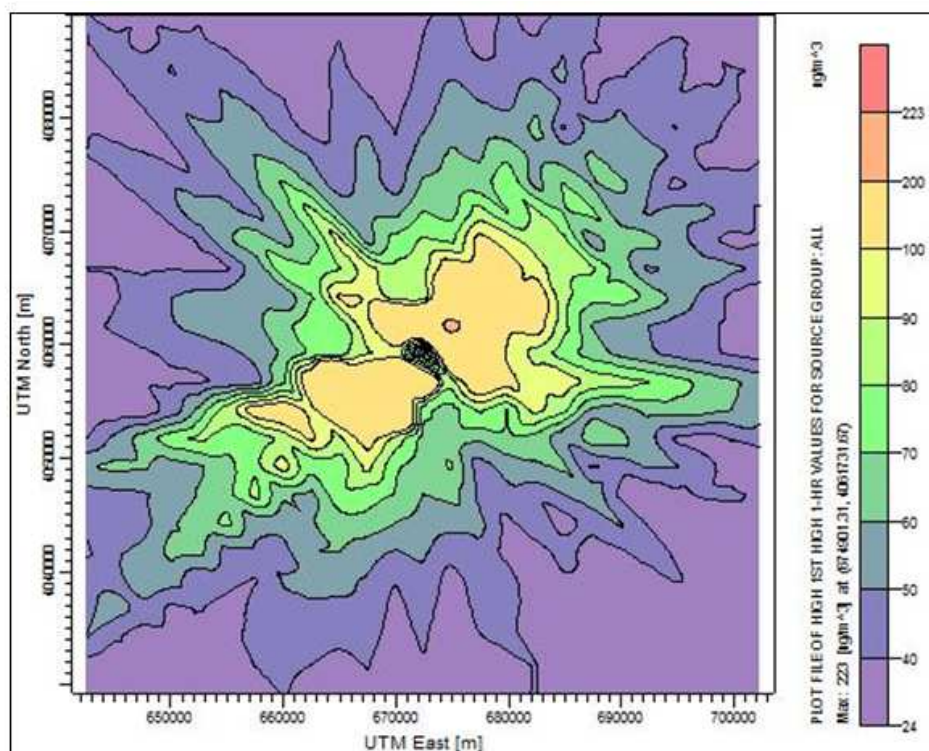

(b)

Fig. 7. (a) Dispersion of PM_{2.5} from Carbon Black (b) Dispersion of SO₂ from Carbon Black

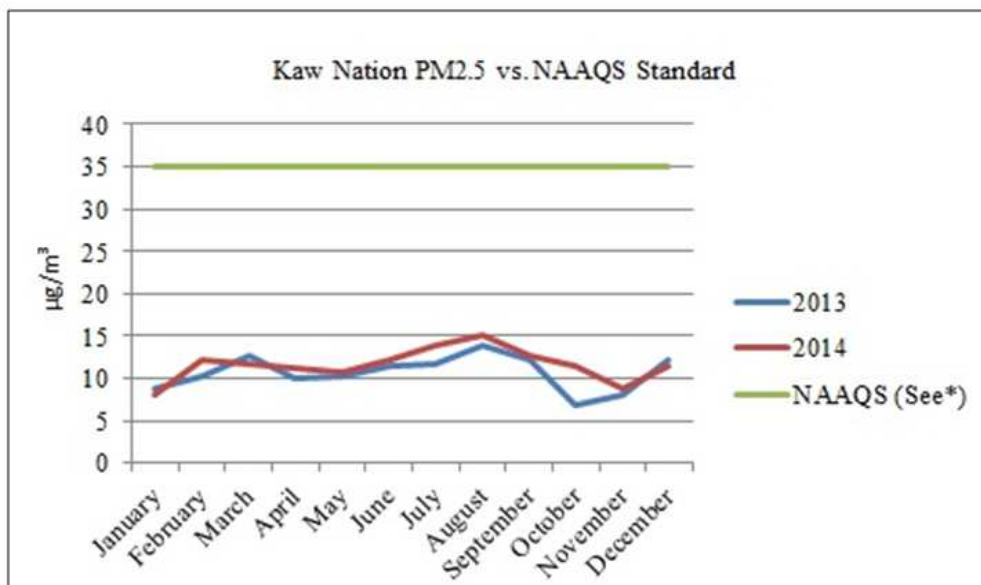

Fig. 8. Kaw Nation Monthly PM2.5 (Source: Kaw Nation); *NAAQS Standard for PM2.5: A 24 h average not to exceed 35 µg/m³; **Months are reported in Monthly Mean

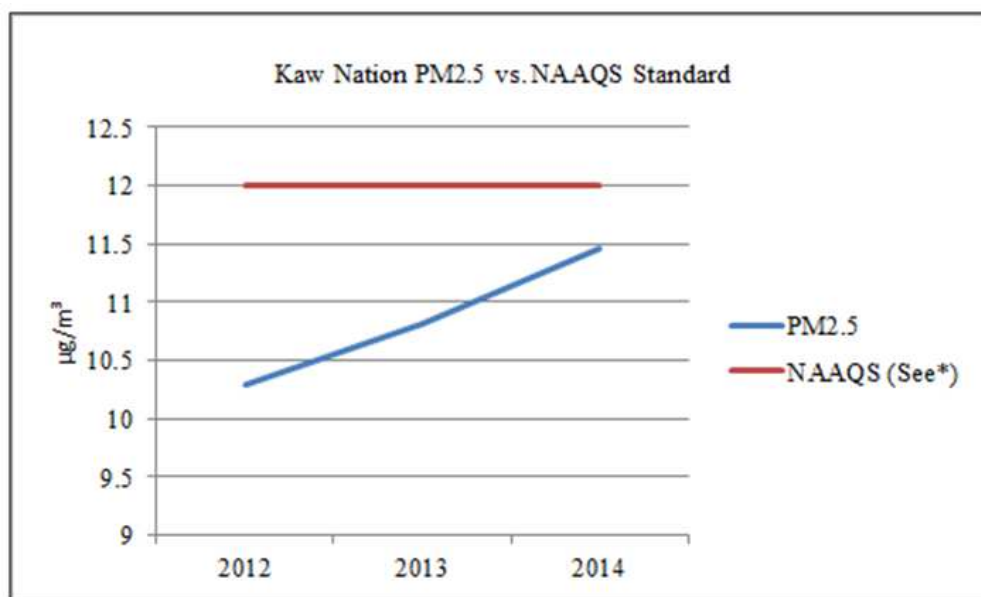

Fig. 9. Kaw Nation Monthly PM 2.5 (Source: Kaw Nation); *NAAQS for PM-2.5 is an annual arithmetic mean not to exceed 12 µg/m³

As per the Kaw Nation Air Quality Monitor, the concentration of PM_{2.5} increased steadily from May to August and showed a decline pattern after October to February (Table 3), this was because of the wind direction and mobility of vehicles. From the month of October to February (winter season) there is less vehicle movement and low emission of PM_{2.5} captured

6.83-10 µg/m³ as shown in Table 3 and Fig. 8. As per Fig. 8, the highest concentrations were observed during the summertime.

Overall, the Kaw Nation monitoring station captured an annual rate of 10 µg/m³ of PM_{2.5}, below the National Ambient Air Quality Standard as illustrated in Table 4 and Fig. 9.

Table 1. Height of stacks and rate of emission

Source	Height (m)	Dia. (m)	SO ₂ Rate (lb/h)	PM _{2.5} Rate (lb/h)	Temp (K)
Power Pl.	152.44	6.1	407.73	43.16	402.04
Power Pl.	152.44	6.1	407.73	39.80	402.04
Refinery	36.58	1.8	17.98	0.22	606.48
Refinery	33.53	2.0	11.00	0.10	652.04
Refinery	30.48	1.2	6.00	0.19	606.48
Refinery	48.77	2.2	14.00	0.18	493.15
Refinery	52.43	3.0	25.00	0.89	574.26
Refinery	38.10	2.2	16.00	0.49	777.59
Refinery	20.12	1.3	3.00	0.10	606.48
Refinery	16.76	1.8	8.00	0.20	606.48
Refinery	44.20	2.1	8.00	0.22	608.15
Refinery	45.72	1.8	8.00	0.19	620.93
Refinery	40.54	1.5	8.00	0.18	606.48
Refinery	30.48	0.9	8.00	0.04	606.48
Refinery	22.56	0.9	4.00	0.11	606.48
Refinery	18.29	1.0	24.80	0.14	606.48
Refinery	42.67	2.4	18.00	0.62	620.37
Carbon Pl.	45.72	3.5	123.44	2.23	1199.82
Carbon Pl.	45.72	2.9	124.48	1.58	1199.82
Carbon Pl.	64.92	2.1	202.57	2.50	1199.82

Table 2. Emission reaching tribal land

Point Source	Emission at point source $\mu\text{g}/\text{m}^3$		Emission reach tribal site $\mu\text{g}/\text{m}^3$		Ave.
	PM _{2.5}	SO ₂	PM _{2.5}	SO ₂	
Power Plant	16	205	3 (19)	50 (24)	21%
Refinery	8	259	2 (25)	70 (27)	26%
Carbon Plant	5	223	1 (20)	40 (18)	19%

Table 3. Kaw nation air monitor

Month	2013	2014
January	8.68	7.93
February	10.27	12.22
March	12.67	11.75
April	9.97	11.31
May	10.19	10.77
June	11.49	12.29
July	11.64	13.82
August	13.91	15.14
September	12.15	12.55
October	6.83	11.40
November	8.07	8.72
December	12.22	11.43

Table 4. Kaw nation yearly PM_{2.5}

Emission	2012	2013	2014
PM _{2.5} ($\mu\text{g}/\text{m}^3$)	10.29	10.82	11.47

Conclusion

The release of PM_{2.5} and SO₂ from the coal generated power plant and the hydrocarbon refinery in Kay County were computed using the Gaussian dispersion model (AERMOD). According to the model, about 6 $\mu\text{g}/\text{m}^3$ of the total emissions reached tribal land.

On the other hand, higher concentration of PM_{2.5} was captured during the summer time (10 $\mu\text{g}/\text{m}^3$) at

the Kaw Nation monitoring station. The pollutants released from the power plant, refinery and carbon black plant PM_{2.5} and SO₂ were below the National Ambient Air Quality Standard. The higher concentration of PM_{2.5} observed during summertime might have come from vehicles and ambient atmosphere due to burning and agricultural activities. In all cases, the PM_{2.5} and SO₂, that reached the tribal land was below the NAAQS, proving that the site is in an attainment zone and the concentration of the pollutant comes not only from the power plant and the refinery, but also from other sources mainly vehicles and ambient atmospheric air dispersion.

Acknowledgment

We would like to thank the U.S. Environmental Protection Agency Region 6 for funding this study. We would also like to thank Dr. Jesse The and Michael Hammer, Lakes Environmental Software for training the Authors to run the AERMOD program. On behalf of the Environmental Department, the authors sincerely appreciate Elaine Huch, Kaw Nation Chair for her encouragement and full support to conduct Air Quality Research that is related to the health and environment of Kaw Nation.

Funding Information

Financial support for this study was provided by U.S. Environmental Protection Agency, Region 6, Dallas, Texas.

Author's Contributions

Dejene Alemayehu: Writer of the Article.

Francine Hackett: Run the computer model and prepared the graphs.

Ethics

This is an original research paper prepared by the authors. No ethical issues that will be raised. Outside information are all referenced.

References

Cimorelli, A.J., S.G. Perry, A. Venkatram, J.C. Weil and R.J. Paine *et al.*, 2004. AERMOD: A dispersion model for industrial source applications. Part I: General model formulation and boundary layer characterization. *J. Applied Meteorol.*, 44: 682-693. DOI: 10.1175/JAM2227.1

Lathe, S. and P. Shamugam, 2010. Proceedings of the 37th National and 4th International Conference of Fluid Mechanics and Fluid Power, (MFP' 10), IIT, Madras, Chennai India.

LES, 1996-2015. Course notes on AERMOD, Gaussian plume, air dispersion model. Lakes Environmental Software.

MacDonald, R., 2003. Theory and objective of air dispersion modeling. *Modelling Air Emissions for Compliance*, MME 474A, Wind Engineering.

Masters, G.M., 1997. Air Pollution. In: *Introduction to Environmental Engineering and Science*, Masters, G.M. (Ed.), Prentice Hall, USA, ISBN-10: 0131553844, pp: 327-452.

ODEQ, 2011. Requested data from ODEQ air emission data for Kay and Noble Counties. Oklahoma Department of Environmental Quality.

U.S. EPA, 2004. User's Guide for AMS/EPA Regulatory Model-AERMOD. U.S. Environmental Protection Agency, EPA 454/B-03-001.