

Design of Economical Equipment for Water and Fuel Level Detection in Jordan

Ali. M. Othman
Mechanical Engineering Department, Philadelphia University,
11931, P.O. Box 1, Jordan

Abstract: Both a cold and hot water supplies in Jordan are provided by indirect systems and so is the fuel supply for central heating, by using storage tanks placed over the buildings roofs. This requires climbing to the roofs for measuring the level of fluid in these tanks. This method is primitive, impractical and tedious. A simple reliable easing system is designed, manufactured and tested for solving the existing problems associated with the already used method. The equipment measures the level of cold water and fuel and also allows the measurement of the temperature of the hot water and displays them on a board inside the user's house with an accuracy of 2 – 3 %, which is acceptable in such applications. However, when the measurement is taken for payment purpose the fuel level should be measured exactly. Also the system indicates when the water arrives from the main supply. The described equipment is small in size and weight and of low power consumption; in addition it requires minimum maintenance, which makes it cost effective. However the model needs testing in freezing point of used liquids. Also the device requires further development in order to solve other problems facing building services in Jordan.

Keywords: Water level, fuel, measurement, equipment, tank, Jordan

INTRODUCTION

It is known that the cold water supply for residential and other types of buildings can be classified as a direct or indirect system as shown in Figure 1. However, some authorities allow some modifications to be made for these systems^[1]. The direct system is used extensively, where large high – level storage cisterns provide a good main supply and pressure. In this system all sanitary fittings are supplied with cold water directly from the main supply. In the other system, indirect system, all of the sanitary fittings are supplied indirectly from a cold – water storage tank(s) often fitted upon the roofs of the buildings usually with a capacity of (1-2) cubic meters^[2]. The adoption of a proper system depends mainly on the availability of water resources in the country. Countries of poor water resources are obliged to adopt the indirect system supply due to the limitation of the quantity of cold water that can be supplied to houses by the water supply authority.

According to local and international sources it is clear that Jordan is a developing country with 5.5 million inhabitants and ranked among the last ten water-poorest countries in the world as indicated in Figures 2 and 3^[2,3]. Therefore, a good management of

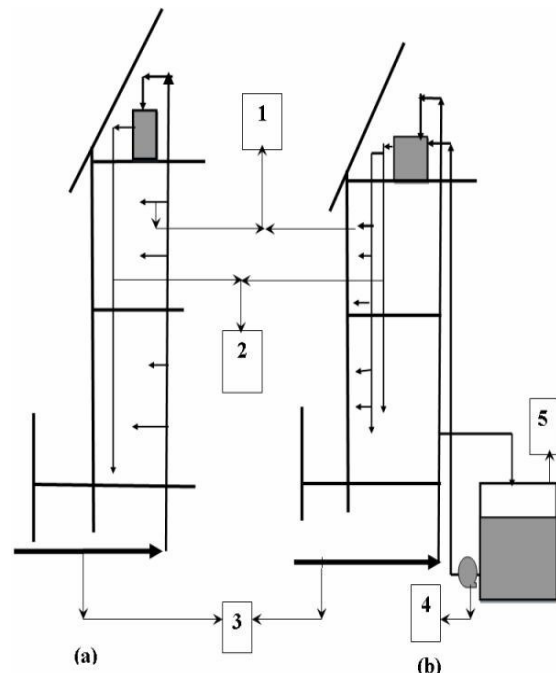

Fig 1: Cold water supply systems. (a) Direct; (b) Indirect 1- Cold water flow to basin, bath..., 2- Flow to heater's small tank, 3- Water main supply, 4- Pump, 5- Underground well(tank)

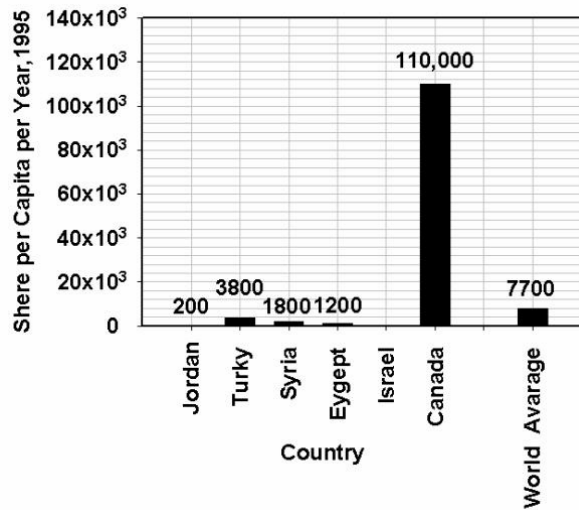

Fig. 2: Water consumption per capita shares per year in cubic meters, 1995

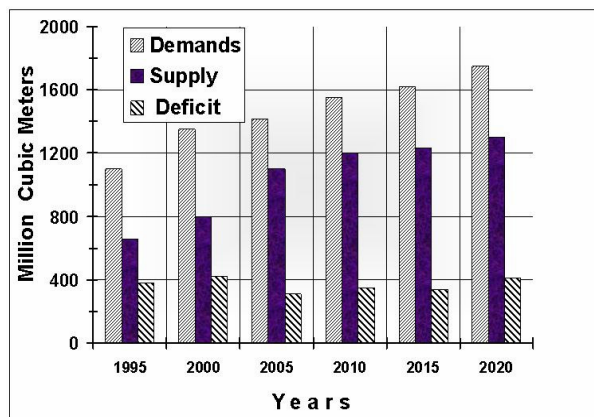

Fig. 3: Water resources in Jordan

water resources and any saving in water consumption is an important issue. In Jordan the indirect system of cold water supply is applied for a long time in all districts of the country. In spite of all long-term plans and attempts aimed to find new resources, the major sources of water are still from artesian ground water wells and recycled waste water [2]. Water from artesian ground water wells and after treatment is pumped and conveyed to large cities and towns by local authority pipes network. Before water distribution to occupants, it is collected again in elevated large storage cisterns or gravity tanks situated at the highest levels in the cities, then water is distributed to houses from these tanks according to different criteria in summer and winter by advance pronounced weekly schedule for each district in the

city. This schedule is fixed and strict in the whole season [2].

Water from city storage cisterns is distributed to residential or other buildings generally for a period of (12-20) hours weekly [2]. Occupants store their needs water upon the roofs of houses or buildings in cold water storage tank(s), the capacity of each tank is one or two cubic meters. This quantity of water is not enough for average large Jordanian family, which consists of six persons. Therefore, occupants in the past decades solved the problems of insufficient quantity and pressure from authority main supply, by building in a private well with a capacity of (20-30) cubic meters from which the water is raised to tanks on the roofs by centrifugal pumps.

In spite of the short period of winter season in Jordan, the central heating system became, in the last twenty years, an essential part of the building services systems. This system in addition to heating function it is used also to heat water. Most boilers of such systems use diesel as an exclusive fuel source. The fuel is also stored in a tank at ground level in the basement, and located as far as possible from the building to avoid bad smell and fire hazard. The capacity of each tank ranges from 1000 to 2000 liters. Also the boiler and radiators in the central heating system needs a small cold water tank usually with a capacity of 500 liters.

PROBLEMS ASSOCIATED WITH EXISTING SYSTEMS

It can be seen from the previous introduction that each house or apartment requires at least six storage tanks to manage the problems associated by adopting indirect cold water supply and central heating systems, (two tanks for cold water, two for hot water, one for water needed for heating system and one for fuel). It is therefore, necessary to explain how current system works and why the levels of water and fuel must be measured and displayed in the user's house. This is discussed in the following sections:

Cold water storage tanks: The problems facing the cold water storage tanks can be characterized as follows:

- a) Due to the limitation of quantity of water delivered weekly to houses, it is essential to know the real quantity of water left in tanks in order to optimize the use of the remaining quantity of water, which saves water. Saving water is an important issue in a country having very poor water resources like Jordan.

- b) On the other hand it is known that the landscapes of most of the inhabited areas of the country are hilly areas specially the Capital city, Amman, in which lives more than 25% percent of the inhabitants of the country. This causes the cold water supply system to work under insufficient pressure. This pressure is lower than that required to raise water to the tanks, therefore people will not know how much water exists in their tanks especially in summer season. To treat this problem the people normally use one of the following:
 - (i) pumping water from ground tank or well (if exists) which increases pumping cost. In addition, when the tank is filled a lot of water will spill from the storage tank on the roof, or
 - (ii) waiting for another week (according to fixed schedule), or
 - (iii) buying the required quantity of water from private suppliers with a price ten times higher than the water authority price.
- c) Each underground private well has a capacity of (20-30) cubic meters of water. This water is stored until it is needed. However, in real practice this water can't be totally consumed, so part of it remains stored for a long time, and will be contaminated. Knowing the water level continuously, enables consumers to guesstimate the period of storing water, then they can decide what to do: either discharge all water and clean the well or sterilize it, or taking samples for water testing ... etc.
- d) In case of emptying boiler's cold-water tank for any reason, this will cause total damage of the boiler.

Fuel storage tank : The problems facing the fuel tank of the central heating system can be characterized as follows:

- a) In the case if the diesel is suddenly finished, the burner will stop running. This can cause serious problems to the burner, as it will use the residue of the fuel, which is contaminated at the bottom of the tank.
- b) After refilling the burner, it requires maintenance, venting and cleaning which will add extra cost.
- c) It is inconvenient to occupants, because they must wait several hours in order to refill the tank again, which is not comfortable in the cold days of winter, but in the case of displaying the fuel level in the house, they can arrange refilling of fuel tank in advance from the fuel delivery agent.

Hot water tanks: Each apartment or house has two storage tanks for hot water supply, one is located at the roof and heated from the solar heating system, the other is located in the basement and heated from the central heating system. The level of water in these tanks is related to the level of water in the cold water tanks, so there is no need to measure the level there, but it is important to measure and display the temperature in each tank in order to warn the occupants if they have enough hot water for domestic use or not. Now this problem is solved by increasing the working time of the boiler. (In winter season the time required to heat the water in the tank of a capacity of 300 liters is about one hour)

Arrival of water from the main supply: Water is distributed to houses from authority main supply according to an advance pronounced weekly schedule, but the exact time (hour) of arriving is not known to people. In the present time, people are not aware about the exact time of water arrival.

In Jordan, the only method used for measuring water and fuel levels in the tanks is to climb on the roof and use a graduated rod or eye judgment through direct observation, and there is not a built in device for this purpose. Also the temperatures of hot water tanks are not measured and people don't know the exact time of water arrival to their tanks.

The problems appear so simple but they are causing the people in Jordan many inconveniences as most of houses in Jordan do not have continuous and direct water supply but have storage tanks.

Design of The System: As mentioned earlier, the indirect cold water supply is used in Jordan (Figure 1, a). The suggested system is designed to serve a typical house or apartment in residential areas in cities or villages. In the previous section it was discussed how current system works without measuring and displaying the fluid level and temperatures in tanks.

Figure 4 shows the designed system for a typical apartment or house in Jordan, with six storage tanks (two tanks for cold water, two tanks hot water, one tank for cold water in heating system and one tank for fuel). Figure 4 also shows the incoming water supply from main water supply. The designed system provides the following functions:

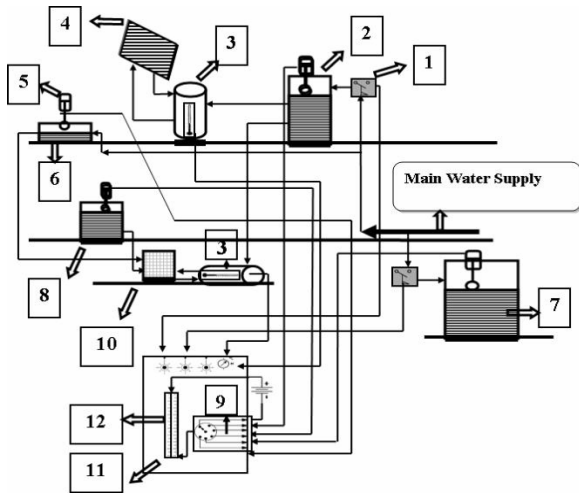

Fig. 4: Designed system

1- Flow actuated switch, 2 - Cold water tank, 3 - Hot water tank, 4 - Solar collector, 5- Fluid level measuring device, 6- Boiler's cold water tank, 7- Underground well(tank), 8- Fuel tank, 9- Selective switch,10 - Boiler, 11-User's indoor board, 12 -Tank's level scale

- Detect and indicate the level of cold water and fuel in the corresponding tanks.
- Measure and indicate the temperatures in the two hot water tanks.
- Indicate the arrival of water from the main supply, which allows maximizing the use of water in gardening, laundry ...etc.

Description Of The Designed Measuring Device:

Numerous types of measuring liquid level devices utilizing different concepts were reported in literature and used for different applications these include [4]: The simplest and oldest industrial level-measuring device is the graduated manometer glass. Other level detection devices include those based on specific gravity, the physical property most commonly used to sense the level surface; in this case a simple float can be used. Hydrostatic head measurements (e.g., displacers, bubblers and differential pressure transmitters); have also been used to infer level [5]. When more complex physical principles are involved, emerging technologies (e.g., ultrasonic, radar, and laser), often use computers to perform the calculations [6].

In order to measure the levels in cold water and fuel tanks, a level measuring device has been designed , manufactured and calibrated successfully after designing several models and prototypes with different principles. It is obvious that numerous types of level measuring devices are known and can be used to do the

job, but in this case, the main objective was, to design and manufacture a device able to do the job, to be acceptable for the local market cost and to be manufactured locally. The main points, which were considered in designing the device, are:

- It should be simple, with low cost and low power consumption.
- It has an acceptable accuracy for such applications.

Fig. 5 and 6 show that the measuring device, consists from a simple float hanging at one side of the device and located at fluid surface. The float has a specific gravity less than the measured fluids (water and fuel); it will rise and fall according to the fluid level. At the other side, a balancing weight is hanging to balance the buoyant force and the float weight. Both of them are connected to ropes wrapped at two pulleys each one produces moment at shaft 1 with opposite direction. Pulleys are mounted on shaft 1 having a suitable diameter and rotating in journal bearings. The rotation of shaft 1, which initiated from float and counter weight, is transmitted to a potentiometer by shafts 2 and 3, worm and wheel assembly, and gears 1 and 2, as shown in figure 5. The dimensions and weights of

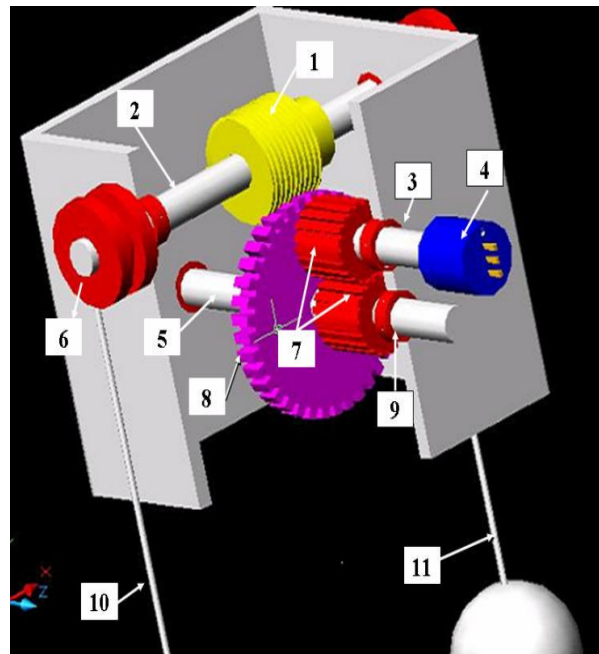

Fig. 5: Fluid level measuring device

- 1 - Worm, 2 - Shaft 1, 3- Shaft 3, 4 - Potentiometer, 5 - Shaft 2, 6- Pulley 1, 7- Gears 1 & 2, 8 - Wheel, 9- Bearing, 10 - Rope attached to float, 11- Counter weight

shafts, pulleys, worm, wheel, bearings and gears have been calculated and selected with different dimensions to give the required (smooth and small) rotation of potentiometer with respect to the fluid level in tanks. This type of motion transition enables the device to measure high and low levels of fluids, and can be easily modified to any specific needed conditions. The signal from the potentiometer is then transmitted through wires to a simple processing circuit to user's indoor board. Most of the components used in the device are made from plastic or non-corrosive materials in order to avoid corrosion and to reduce the cost and weight. The friction between gears is reasonable and the rotation is smooth. The power supply for the device is low and far from the fuel tank, so there is no risk of fire. The weight and size of device are small and it requires minimum maintenance. The accuracy is 2-3 %, which is acceptable for such applications; also, it is not affected by ambient and measured fluid pressure and temperature. The indoor user's board has the following indicators:

- One vertical light indicator for measuring water and fuel levels.
- Selective switch to check the level in a specific tank.
- Two light indicators, works only during the filling process of water in tanks.
- One thermometer to indicate the hot water temperatures in tanks.
- On/off switch.

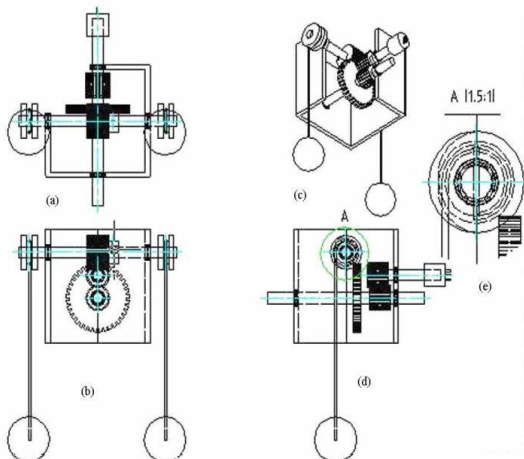

Fig. 6: Different views of fluid level measuring device

RESULTS AND DISCUSSION

The measuring device was checked using stainless steel ruler. The readings were taken every (15-25) mm level and the reading of the device against the ruler reading where recorded, starting from 100- mm up to 1100- mm level. The same procedure was repeated by lowering the level from (1100 to 100) mm. The results were tabulated and drawn as shown in figure 7. It can be seen from this figure that the relationship between the ruler and the device readings is linear and can be fitted by the following equation: $H = 7.0008 + 3.3352 \times x$ Where, x is device's reading, H is ruler's reading, which indicates that the device is accurate enough for measuring the level of liquids in tanks.

The device will measure the level for indication purposes and requires further development to enhance the accuracy to be applicable for payment purpose and to solve other problems facing building services in Jordan such like the domestic gas supply and the

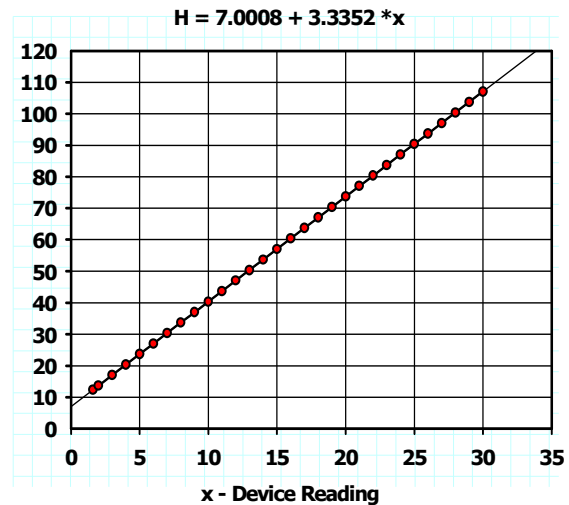

Fig. 7: Device calibration curve

automatic refilling of upper tanks from underground wells. The device hasn't been tested in freezing condition, but this situation seldom happens in Jordan. Serial production of the device will be discussed later with manufacturers after fulfilling the required documentations for a patent from the directorate of industrial property protection in Jordan. Finally, in future efforts will be done to convince the ministry of water and irrigation in order to adopt the system, particularly in new buildings and houses.

CONCLUSION AND RECOMMENDATIONS

A simple and reliable device is designed, manufactured and tested together with a designed system to be used in connection with the indirect cold water supply system and diesel fuel supply for low-pressure central heating in Jordan.

The system enables the user to know when water from the main supply discharges to the cold water tanks. The levels of water and fuel in tanks are measured and displayed. The temperatures of hot water tanks are also measured and displayed. The system is simple, safe, having low weight and size, non-corrosive and has acceptable accuracy. It requires minimum maintenance and hence cost effective. Finally, the system may be applied in other developing countries having indirect water supply and diesel for central heating as in Jordan. Although the accuracy of the device is 2-3 %, which is accurate enough for indicating purposes but not accurate enough when the measurement is considered for payment purposes and further development must be done in future.

ACKNOWLEDGEMENTS

I would like to acknowledge the technicians of the workshop of mechanical engineering department at Philadelphia University for the share of manufacturing some components of the device.

REFERENCES

1. F. Hall Plumbing, 1994. Cold Water Supplies, Drainage and Sanitation. Longman Scientific & Technical. Malaysia
2. Ministry of Water and Irrigation, Regulations, 1995 Hashemite Kingdom of Jordan (HKJ).
3. I. Abu-Shams, I. Dahiyat, June 2004. Private sector participation: A Tool for effective water demand management in Jordan: Proceedings of the International Water Demand Management Conference. Dead Sea, Jordan.
4. U.S. Department of Energy, 1992. Fundamentals Handbook , Instrumentation and Control volume (1), Module 3 , Washington, D, C, USA
5. J.G. Webster, (Editor-in-Chief), 1999. Measurement, Instrumentation and Sensors Handbook. CRC Press LLC, Section II.11
6. K. Hambrice, H. Hopper, 2004. A dozen ways to measure fluid level and how they work: K-TEK Corp. Sensors,